

Experiment T472

Test of differential Čerenkov counter for η - and ω - mesic nuclear search (Titech-Tokyo)

We have developed new position sensing and β selection type Čerenkov counter (POSCH) for η - and ω - mesic nuclear search (S214) (GSI,Germany). The detection of the exotic nuclear signatures requires the measurement of the momentum of helium-3, under the recoilless condition of the ${}^7\text{Li}(d,{}^3\text{He})$ reaction. Because of the incident deuteron breakup at the target, a huge number of protons are expected as severe background for the measurement. The estimated number of the proton background is larger than 10^8 /sec.

The POSCH detector is designed to be insensitive to the proton background and to measure the hit position (momentum) of the helium-3 under such a high background rate. The purpose of the T472 experiment is the performance test of the prototype POSCH detector. At KEK-PS $\pi 2$ line, we used proton beam in two different momenta. At the fast 2.52 GeV/c ($\beta=0.93$) mode, the background (proton) rejection capability was studied. The rejection is realized by the total reflection of Čerenkov photons at the surface of the radiator (acrylic resin). The proton background, which have higher velocity than the helium-3, makes larger emission angle of Čerenkov radiation than the critical angle (Fig.1). And at the slow 1.69 GeV/c ($\beta=0.87$) mode, the position resolution for the helium-3 was studied by using the proton. After the gain calibration of six photomultiplier tubes (PMT), the center-of-mass of the PMT's outputs gave the hit position.

As the result of the test experiment, the background rejection capability is better than 10^{-3} for the wide incident angle of ± 60 mrad with good helium-3 detection efficiency of more than 98 %. The position resolution for the helium-3 was evaluated to be ~ 2 mm in σ (Fig.2). The test experiment proved that the POSCH detector has enough performance for the S214 η - and ω - nuclear experiment.

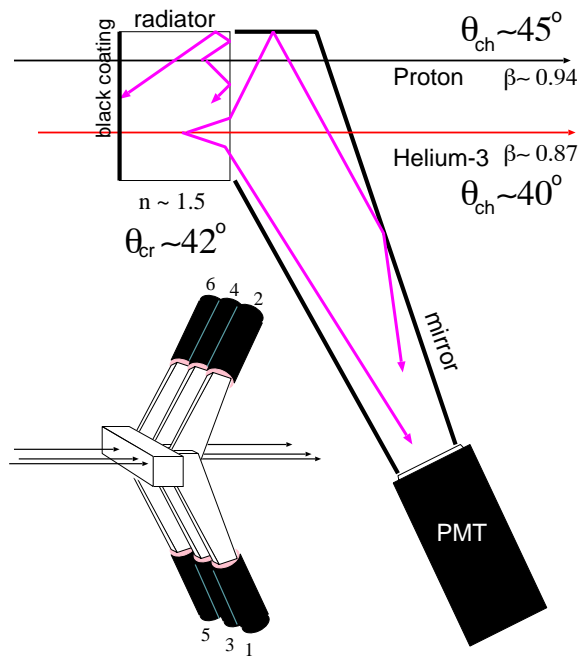

Figure 0.1: (left) Back side of the detector (partially without rear covers) (right) The principles: Čerenkov radiation and total reflection

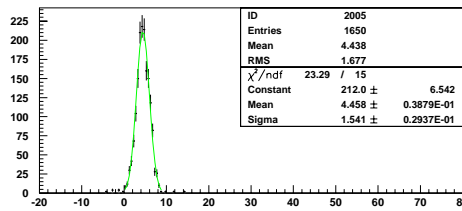
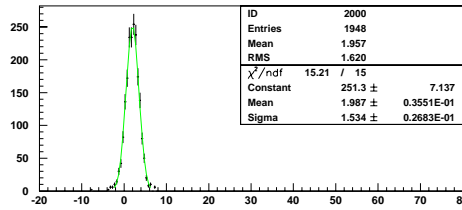
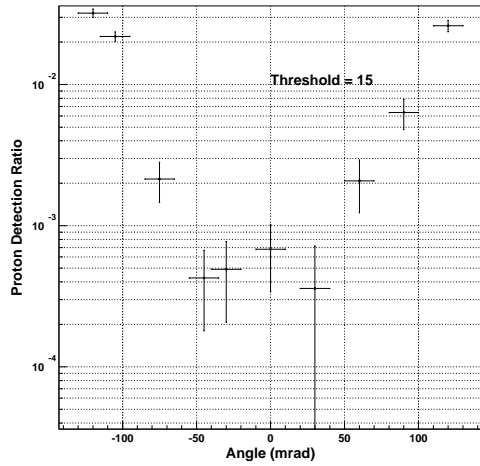

Figure 0.2: (left) Detection ratio of background proton at various incident angle. (right) Simulated position resolution for the ${}^3\text{He}^{2+}$: Hit position; 0 mm and 2.5 mm